

# Study on multi-size seed-metering device for vertical plate soybean precision planter

Liu Hongxin\*, Guo Lifeng, Fu Lulu, Tang Shifa

(College of Engineering, Northeast Agricultural University, Harbin 150030, China)

**Abstract:** Aiming to solve the problem of small range of the appropriately sowing seeds existing in a vertical disc seed-metering device, the planter plate series with four sizes were developed according to the variety and size distribution of all soybeans in China. The structure and working principle of the vertical disc soybean seed-metering device were detailed, and the influence of the diameter of soybean on the working performance of the seed-metering device was analyzed through the software EDEM virtual simulation, so as to achieve the goal of covering the soybean seeds with all sizes by the minimum planter plate series as well as to obtain the most appropriate operating speed of each planter plate by optimization. For the planter plates with the hole diameter of 7, 9, 12, 16 mm, the appropriate size ranges of sowing seeds are 4.5-6.0, 6.0-8.0, 8.0-10.5, 10.5-13.0 mm, respectively, and the appropriate operating speeds are 9, 8, 7, 6 km/h, respectively. The results show that this planter plate series can meet the requirements of seeding with all sizes of soybeans at the range of the most appropriate operating speed. The study method can provide a reference for design and optimization of precision planters.

**Keywords:** precision planter, seed-metering device, soybean seed, hole size, EDEM simulation, planter plate series, optimization

**DOI:** 10.3965/j.ijabe.20150801.001

**Citation:** Liu H X, Guo L F, Fu L L, Tang S F. Study on multi-size seed-metering device for vertical plate soybean precision planter. *Int J Agric & Biol Eng*, 2015; 8(1): 1–8.

## 1 Introduction

The vertical disc, with the characteristics of compact structure and convenience in transmission, is one of the major forms of seed-metering components of domestic and foreign precise seed-metering devices<sup>[1-4]</sup>. The seed-metering device mainly consists of left and right housings, a compound planter plate, shafts and a seed shield, etc. The operating principle of this seed-metering device is described as follows: After the seed moves from

grain tube to the seed cavity, it goes into the hole by gravity and lateral filling power, and arrives at cleaning area under the rotation of the sowing axle. Only one seed stays in the hole, the extra seeds return to the seed cavity under their own gravity. After going into the protecting area, the seed reaches the throwing area under the protection of seed shield. Then the seed is projected out under gravity and centrifugal force from the seed hole. The outstanding feature of its structure is that, all parts except for the seed shield and its component are fully symmetrical structures, with good manufacturability<sup>[4,5]</sup>. The vessel for seed-metering of the soybean is known as the hole, which influences the accuracy of the device directly not only by its shape, geometric size and arrangement state of the seed in it, but also the shape and size of the seed which states in it.

Most of the seed-metering device can seed precisely under the certain region size of the soybean. But there are wide varieties of soybean in China and the size distribution is wide, the difference is large<sup>[6-8]</sup>, if the

**Received date:** 2014-09-02    **Accepted date:** 2015-01-05

**Biographies:** **Guo Lifeng**, Majored in agricultural mechanization engineering. Email: lifeng\_guo@126.com. **Fu Lulu**, Majored in agricultural mechanization engineering. Email: 18946004557@163.com. **Tang Shifa**, Majored in agricultural mechanization engineering. Email: tsfneau@163.com.

**\*Corresponding author:** **Liu Hongxin**, PhD, Professor, doctoral tutor. Majored in agricultural mechanization and automation. Address: College of Engineering Northeast Agricultural University No.59 Mucai Street, Xiangfang District, Harbin, Heilongjiang Province, China. Email: lcc98@neau.edu.cn. Tel: +86-451-55190338.

soybean sizes changed exceeding a certain range, these devices could not seed precisely. So the seeds are always graded and different planter plates should be selected to make sure the precise seed metering, which needs a number of planter plates to meet the large wide varieties soybean. This would increase the cost and be inconvenient to use. In this case, the authors of this paper developed a planter plate series with four sizes, according to the varieties and size distribution of all soybean varieties in China, to meet the requirement for precisely seeding by changing the base diameter of the hole ( $d_0$ ) on the basis of the primary hole shape, and through virtual simulation to achieve the goal of covering all sizes of soybean seeds with the minimum planter plate series.

## 2 Materials and methods

### 2.1 Equivalent diameter of soybean seeds

Total 215 portions of soybean seed samples were selected from six ecological zones of cultivation in China<sup>[9,10]</sup>, and 100 seeds were picked out randomly from each kind of soybean by using a vernier caliper with accuracy of 0.02 mm to get their grain length ( $L$ ), grain width ( $W$ ) and grain height ( $H$ ) distribution, as shown in Figures 1-3, respectively. The equivalent diameter of soybean  $D_p$  (mm) and the spherical rate of soybean  $\phi$ <sup>[11]</sup> can be obtained through the following formulas:

$$D_p = (L \cdot W \cdot H)^{\frac{1}{3}} \tag{1}$$

$$\phi = \frac{(L \cdot W \cdot H)^{\frac{1}{3}}}{L} \tag{2}$$

The obtained equivalent diameters of soybean spherized are in the range of  $d = 4.5$ -13.0 mm.

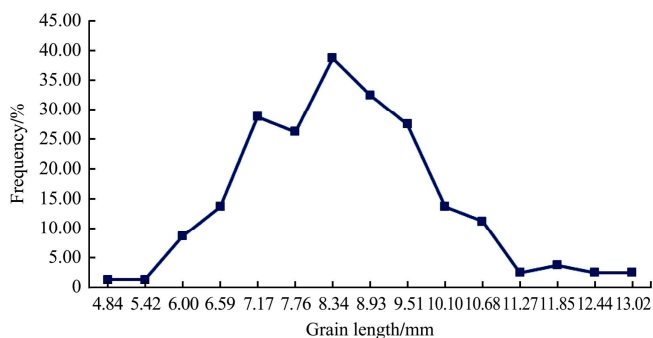

Figure 1 Grain length ( $L$ ) distribution of soybean seeds

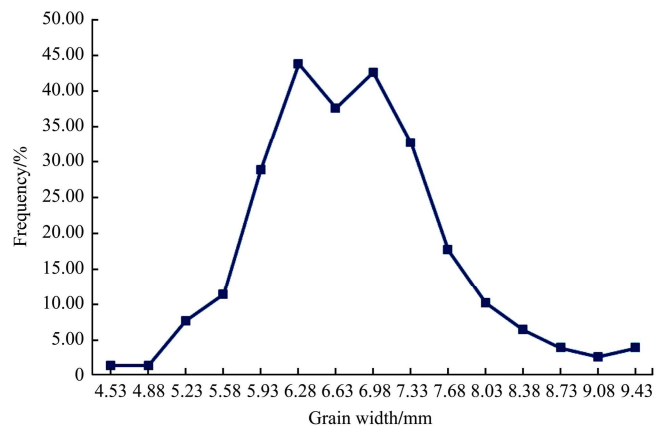

Figure 2 Grain width ( $W$ ) distribution of soybean seeds

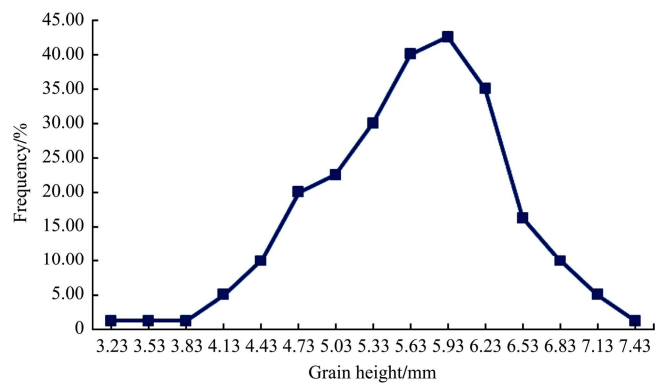

Figure 3 Grain height ( $H$ ) distribution of soybean seeds

### 2.2 Basic parameter of the seed hole

#### 2.2.1 Base diameter $d_0$

The structure of a 2B-JP-FL 01 vertical disc soybean seed-metering device and the configuration and parameters of seed hole are shown in Figures 4 and 5 respectively.

In order to reduce the numbers of the planter plate series and ensure the accuracy of seeding at the same time, we developed the planter plate series with four sizes. Since the equivalent diameters  $d$  of the soybean seeds are within the range of 4.5-13.0 mm, we divided the soybean seed into the following four sizes range: 4.5-6.0 mm, 6.0-8.0 mm, 8.0-10.5 mm, and 10.5-13.0 mm.

According to practical experience, the base diameter  $d_0$  of the hole shall meet the conditions as follows:  $d_{\max} < d_0 < 1.5 d_{\min}$ , where,  $d_0$  is the base diameter of the seed hole;  $d_{\max}$  is the largest equivalent diameter of the soybean seed;  $d_{\min}$  is the smallest equivalent diameter of the soybean seed. The size distribution list of the preliminary design of the seed hole is shown in Table 1.

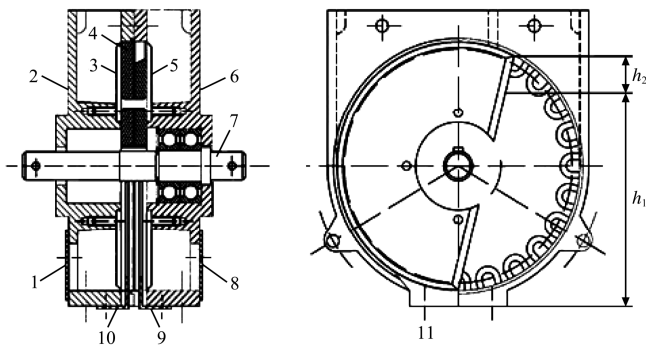

1, 8. Examine the hole cover 2, 6. Left and right housings 3, 5. Left and right seed shield 4. Compound planter plate 7. Shafts and its components 9, 10. Left and right assist seeding tongue 11. Seed exit 12. Seed hole (Figure 5)

Figure 4 Components of 2B-JP-FL 01 seed-metering device

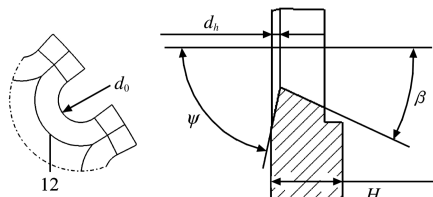

Note:  $d_0$  is the base diameter of the hole;  $d_h$  is the deeps of the guide surface;  $\beta$  is the inner face of the hole;  $\psi$  is the outer face of the hole;  $H$  is the thickness of the planter plate

Figure 5 Configuration and parameters of seed hole

Table 1 Distribution list of the seed hole size

Smallest equivalent diameter of soybean seed $d_{min}/mm$	Largest equivalent diameter of soybean seed $d_{max}/mm$	Base diameter of seed hole $d_0/mm$
4.5	6.0	7.0
6.0	8.0	9.0
8.0	10.5	12.0
10.5	13.0	16.0

### 2.2.2 Thickness of planter plate $H$

The thickness of the planter plate should be less than the maximum equivalent diameter of the seed, two seeds cannot be accommodated in the same hole at the same time. Therefore, the thickness of the planter plate should be taken as the maximum equivalent diameter of the same series of seeds, namely of the round numbers the thickness of the four planter plates are  $H_1 = 6$  mm,  $H_2 = 8$  mm,  $H_3 = 11$  mm, and  $H_4 = 13$  mm.

To make sure the four planter plates with different thicknesses can be used in the same seed-metering device without replacing its housing, we need to radially regulate the seed shield connected with the planter plate by installing an adjusting shim on the fixed plate of the housing. Four adjusting shims were made and the shape of their end faces were processed the same as that of the fixed plate on the housing, as shown in Figure 6. The

thickness  $h$  values of the adjusting shims matching with the four planter plates respectively are as follows:  $h_1 = 9$  mm,  $h_2 = 7$  mm,  $h_3 = 4$  mm, and  $h_4 = 2$  mm. While replacing the planter plate, the corresponding adjusting shim needs to be replaced.

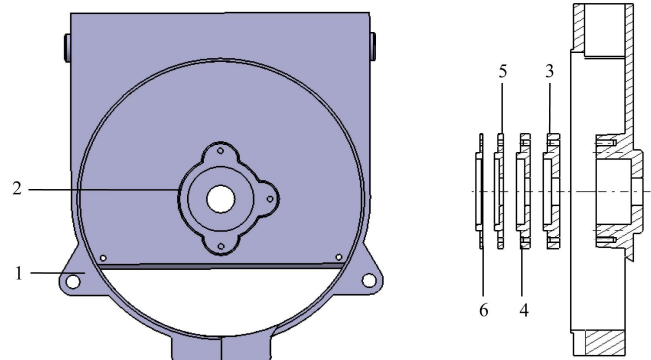

1. Housing 2. Fixed plate 3-6. Adjusting shim series  
Figure 6 Adjusting shim for installment

### 2.2.3 Seed hole configuration $m_k$

The excircle diameter of the hole  $d_z$ , the base diameter of the planter plate  $d_j$ , and the number of the holes  $m_k$  can be obtained by the following equations:

$$d_z = d_0 + 2d_h \cdot \tan\Psi \tag{3}$$

$$d_j = d_p - d_0 \tag{4}$$

$$m_k = \pi d_j / d_z \tag{5}$$

where,  $d_0$  is the base diameter of the hole, mm;  $d_h$  is outer guide surface depth, mm;  $\Psi$  is seed filling angle, ( $^\circ$ );  $d_p$  is diameter of planter plate, mm. The parameters  $d_h$ ,  $\Psi$ ,  $d_p$  are the known data of the components of 2B-JP-FL 01 seed-metering device, as shown in Figure 5, in which,  $d_0 = 7, 9, 12, 16$  mm;  $d_h = 1$  mm;  $\Psi = 78^\circ$ ;  $d_p = 200$  mm. Under the premise of keeping the hole shape integral, the number of the hole should be set as much as possible, so as to improve their ability to fill<sup>[1]</sup>, the numbers of the holes  $m_k$  were obtained as 38, 34, 29, and 24 respectively.

## 3 EDEM virtual simulation

While the seed-metering device is working, seeds impact with each other and contact the device as well. So that the working process could be simulated well by the software EDEM based on discrete element method<sup>[12-14]</sup>.

### 3.1 Simulation model establishment and parameter selection

#### 3.1.1 Setting of global variables

Herz model was used for showing forces between the

soybean grains as well as between the soybean grain and the steel wall<sup>[12]</sup>. The simulation parameters were set as shown in Table 2<sup>[15-17]</sup>.

These data were obtained through physics and mechanics experimental determination under the same condition at the temperature of 20°C, and values were the average.

**Table 2 Pre-treatment parameters setting**

Material	Property	Value	Material	Property	Value
Soybean grain	Poisson's ratio	0.25	Soybean-Soybean	Coefficient of restitution	0.60
	Shear modulus/Pa	1.04×10 <sup>6</sup>		Coefficient of static Friction	0.45
	Density/kg·m <sup>-3</sup>	1228		Coefficient of dynamic Friction	0.05
Steel inner wall	Poisson's ratio	0.30	Soybean - Steel inner wall	Coefficient of restitution	0.60
	Shear modulus/Pa	7×10 <sup>10</sup>		Coefficient of static Friction	0.30
	Density/kg·m <sup>-3</sup>	7800		Coefficient of dynamic Friction	0.01

### 3.1.2 Establishment of soybean grain model

In order to more actually simulate the shape of the soybean, the soybean grain model was developed as tetrahedron configuration<sup>[12]</sup>. The model of soybean seed was combined in CATIA software by four overlapping spheres, their diameters were set by equivalent diameter of soybean. The center coordinates of spheres were recorded and these data were imported into the particles module of EDEM, as shown in Figure 7. This combined sphere can simulate the soybean grain with most reality.

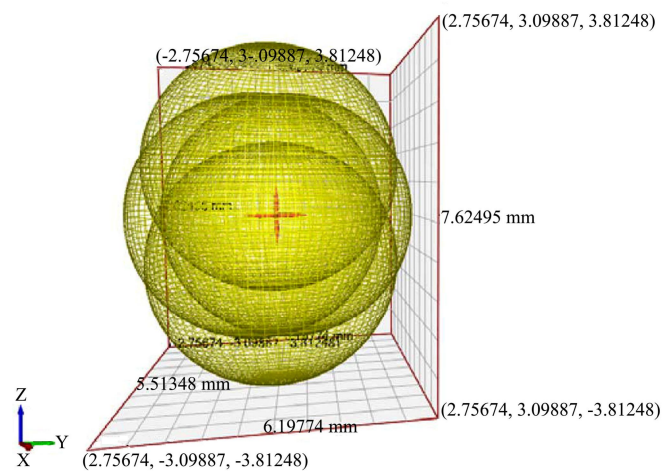

Figure 7 3D graph of soybean grain model

### 3.1.3 Establishment of geometric model

The geometric model was created by CAD and imported into EDEM. The planter plate and the seeding

shaft were set as rotating parts, while the other parts and components were set as fixed members; Then virtual factory was created, i.e., the grain generation range, its area was the cross-sectional area of the upper cavity of the planter plate<sup>[12]</sup>.

### 3.1.4 Setting of soybean grain factor

The amount of the grains and the generation speed were set according to semi-cavity filling requirements. The diameters of the grains complied with the normal distribution. The generated soybean seed samples should have the size distribution covering all sizes of the soybean seeds in the same level.

### 3.1.5 Setting of simulation and calculation

The simulation time was consistent with the end time of rotation of the rotating component. The data storage time was to perform iteration storage once every 5 seconds. The grid size was set as doubling the minimum size<sup>[12]</sup>. When the roller was rotating and all the holes were filled with soybean, we got a picture cut from the simulation process as shown in Figure 8.

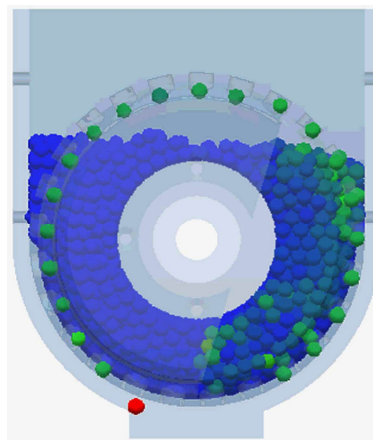

Figure 8 Simulation process graph when the holes were filled

## 3.2 Simulation experiment and factor determination

According to the number of factors and the level and with consideration of interaction between factors, a factorial experiment design method was selected. The equivalent diameter  $d$  of the soybean and the operation speed  $v$  were selected as the experiment factors. The experiment response indicators were cavity rate  $C$  and re-seeding rate  $R$ . Here, cavity means no soybean in a hole, re-seeding means more than one soybean in a hole. The operating speed range of each planter plate was selected through initial screening according to the auxiliary theoretical analysis of simulation. The

experiment groups of each planter plate equaled to the number of equivalent diameter  $d$  of the soybean times the number of operation speed  $v$  in each group. So the test number of each experiment group of the 4 planter plates were  $4 \times 3 = 12$ ,  $5 \times 3 = 15$ ,  $6 \times 3 = 18$ , and  $6 \times 3 = 18$  respectively. The experimental data comparison is shown in Table 3, using the Historical Data module in Design Expert\_6.0.10 to process the experimental data.

The planter plate series were developed with four sizes, the base diameters of the holes on each planter plate were 7.0, 9.0, 12.0, and 16.0 mm respectively. And their appropriate sowing seed were within the range of 4.5-6.0, 6.0-8.0, 8.0-10.5, and 10.5-13.0 mm respectively. In order to make clear their seeding accuracy and find out their appropriate operating speed, a speed scope for each planter plate when seeding was developed, and the highest speed in the condition of precisely seeding with each planter plate was obtained.

**Table 3 Experimental data**

Base diameter of the hole $d_0$ /mm	Feature parameter $d$ /mm	Operation speed $v$ /km·h <sup>-1</sup>
7	4.5-6.0	8, 9, 10
9	6.0-8.0	7, 8, 9
12	8.0-10.5	6, 7, 8
16	10.5-13.0	5, 6, 7

**3.3 Results and analysis**

3.3.1 Experimental results

The four group experiments include different diameters of soybean and different speeds. The results of cavity rate and re-seeding rate are shown in Table 4. We can obtain rules from these data: under the condition of the same diameter of soybean in each group, when the speed turned larger, the cavity rate and re-seeding rate turned larger too, under condition of the same speed in each group, when the diameter of soybean turned larger, the cavity rate turned smaller and the re-seeding rate turned larger.

**Table 4 Parameters and results of experiment**

$d_0$ /mm	Test number	Factor		Performance index		Test number	Factor		Performance index	
		$d$ /mm ( $x_1$ )	$v$ /km·h <sup>-1</sup> ( $x_2$ )	Cavity rate $C$ ( $y_1$ )	Re-seeding rate $R$ ( $y_2$ )		$d$ /mm ( $x_1$ )	$v$ /km·h <sup>-1</sup> ( $x_2$ )	Cavity rate $C$ ( $y_1$ )	Re-seeding rate $R$ ( $y_2$ )
7	1	4.5	8	0.00	1.68	7	5.5	8	1.19	0.36
	2	4.5	9	0.00	2.40	8	5.5	9	2.74	1.09
	3	4.5	10	2.35	3.37	9	5.5	10	17.78	1.23
	4	5.0	8	0.00	1.33	10	6.0	8	1.32	0.00
	5	5.0	9	1.01	0.78	11	6.0	9	3.85	0.40
	6	5.0	10	11.98	1.64	12	6.0	10	23.36	0.33
9	1	6.0	7	0.00	0.77	9	7.0	9	17.34	0.00
	2	6.0	8	0.00	1.23	10	7.5	7	2.07	0.14
	3	6.0	9	5.43	2.48	11	7.5	8	3.13	0.03
	4	6.5	7	0.04	1.02	12	7.5	9	23.47	0.00
	5	6.5	8	0.13	1.61	13	8.0	7	2.10	0.00
	6	6.5	9	13.20	3.20	14	8.0	8	2.85	0.00
	7	7.0	7	1.02	0.37	15	8.0	9	25.77	0.00
	8	7.0	8	1.00	0.44					
12	1	8.0	6	0.00	3.68	10	9.5	6	2.01	1.01
	2	8.0	7	0.03	5.72	11	9.5	7	2.53	1.09
	3	8.0	8	11.07	7.07	12	9.5	8	25.77	1.13
	4	8.5	6	1.11	2.04	13	10.0	6	1.47	0.97
	5	8.5	7	1.09	2.21	14	10.0	7	2.93	1.00
	6	8.5	8	19.36	2.83	15	10.0	8	33.86	1.01
	7	9.0	6	1.63	2.07	16	10.5	6	1.19	0.47
	8	9.0	7	2.20	1.99	17	10.5	7	2.72	0.53
	9	9.0	8	23.14	2.78	18	10.5	8	35.85	0.00
16	1	10.5	5	0.00	3.37	10	12.0	5	0.57	1.27
	2	10.5	6	0.00	3.49	11	12.0	6	1.66	1.01
	3	10.5	7	9.41	4.58	12	12.0	7	33.79	0.99
	4	11.0	5	0.00	2.72	13	12.5	5	2.37	1.00
	5	11.0	6	0.03	3.31	14	12.5	6	4.49	0.83
	6	11.0	7	18.17	5.85	15	12.5	7	45.82	0.13
	7	11.5	5	1.99	1.97	16	13.0	5	3.37	0.40
	8	11.5	6	2.44	3.20	17	13.0	6	4.73	0.12
	9	11.5	7	23.21	3.58	18	13.0	7	47.74	0.00



### 3.3.2 Regression equation

In order to make clear the influence of the experiment factors and the interaction between these factors, a regression analysis should be developed. Imported the data of the experiment results into the Historical Data module in Design Expert\_6.0.10, the software can process and analyze these data automatic. Taking the hole diameter  $d_0 = 7$  mm for example, we perform regression analysis of the cavity rate and the re-seeding rate. In the software,  $y_1, y_2$  stand for experiment response indicators,  $x_1, x_2$  stand for experiment factors. So in this study,  $y_1$  is cavity rate,  $y_2$  is re-seeding rate,  $x_1$  is diameter of soybean,  $x_2$  is operation speed.

#### 1) Cavity rate $y_1(C)$

According to experimental data, the original regression equation of the cavity rate and the experiment factor processed by professional software is:

$$y_1 = 2.3 + 4.36x_1 + 6.62x_2 - 0.72x_1^2 + 5.35x_2^2 + 4.78x_1x_2 \tag{6}$$

The significance experiment of the regression equation is shown in Table 5.

**Table 5 Variance analysis of cavity rate  $y_1(C)$**

Source	Degree of freedom	Sum of squares	Mean square	F value	Critical value
Total	11	678.97			
Model	5	656.35	131.27	34.81	$F_{0.01(5,6)}=8.75$
Residual	6	22.62	3.77		$F_{0.05(5,6)}=4.39$

The  $F$  inspection result shows that:  $F > F_{0.01}, F_{0.05}$ . So the regression equation acquired by the orthogonal experiment has a good fitting relationship with the actual situation.

The actual quantity of the experimental factor was transferred to obtain the regression equation:

$$C = 611.12 - 38.12d - 123.07v - 1.27d^2 + 5.35v^2 + 6.37d \cdot v \tag{7}$$

#### 2) Re-seeding rate $y_2(R)$ :

According to experimental data, the original regression equation of the re-seeding rate and the experiment factor processed by professional software is:

$$y_2 = 0.99 - 1.06x_1 + 0.4x_2 + 0.33x_1^2 + 0.075x_2^2 - 0.26x_1x_2 \tag{8}$$

The significance experiment of the regression equation is shown in Table 6.

**Table 6 Variance analysis of re-seeding rate  $y_2(R)$**

Source	Degree of freedom	Sum of squares	Mean square	F value	Critical value
Total	11	10.32			
Model	5	9.37	1.87	11.89	$F_{0.01(5,6)}=8.75$
Residual	6	0.95	0.16		$F_{0.05(5,6)}=4.39$

The  $F$  inspection result shows that:  $F > F_{0.01}, F_{0.05}$ . So the regression equation acquired by the orthogonal experiment has a good fitting relationship with the actual situation.

The actual quantity of the experimental factor was transferred to obtain the regression equation:

$$R = 10.34 - 4.37d + 0.90v + 0.58d^2 + 0.08v^2 - 0.35d \cdot v \tag{9}$$

### 3.3.3 Graphical analysis

Taking the hole diameter  $d_0=7$  mm for example, the experiment factor combination affects the equivalent curved line and the curved surface as shown in Figures 9, 10.

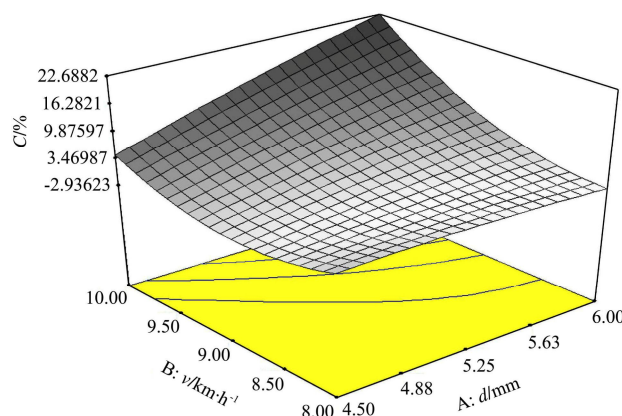

Figure 9 Isovalue contour surface of influences of  $d$  and  $v$  upon cavity rate ( $d_0=7$  mm)

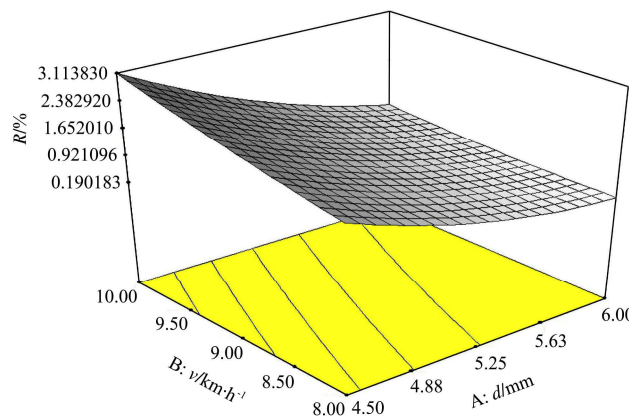

Figure 10 Isovalue contour surface of influences of  $d$  and  $v$  upon re-seeding rate ( $d_0=7$  mm)

By analysis of the curved line and the curved surface diagram, it can be known that the equivalent diameter  $d$

of the soybean has little impact on the cavity rate and the re-seeding rate at a low speed, only play a role accelerated to a certain extent, which indicate the range of the seed equivalent diameter limited by each planter plate is reasonable. The speed  $v$  has a greater impact on the cavity rate and the re-seeding rate; such change shows a significant growth trend when speeding up to a certain value.

Taking the cavity rate  $<5\%$  as a threshold, the most appropriate operating speed of each planter plate was obtained by the experiment result, and the data comparison table was shown in Table 7.

**Table 7 Appropriate operating speed of each planter plate (Cavity rate  $<5\%$ )**

Planter plate series	Base diameter of the hole $d_0/\text{mm}$	Appropriate sowing seed range $d/\text{mm}$	Appropriate operating speed $v/\text{km}\cdot\text{h}^{-1}$
1	7	4.5-6.0	$\leq 9$
2	9	6.0-8.0	$\leq 8$
3	12	8.0-10.5	$\leq 7$
4	16	10.5-13.0	$\leq 6$

### 3.3.4 Verification experiment

In order to verify the truth and reliability of the results of theoretical analysis and virtual simulation, a field experiment was conducted using different sizes soybean in the same series range. The cavity rate and the re-seeding rate could be obtained when the plant plates were seeding the appropriate mixed soybean seeds of each series at their appropriate operating speed. The goal was to further investigate whether the appropriate sowing seed range and the most appropriate operating speed of the planter plates obtained by the above steps was reasonable. Data of the verification experiment were shown in Table 8.

**Table 8 Data acquired from the verification experiment**

Serial number	$d_0/\text{mm}$	$d/\text{mm}$	$v/\text{km}\cdot\text{h}^{-1}$	Cavity rate $C$	Re-seeding rate $R$
1	7	4.5-6.0	9	2.14	1.01
2	9	6.0-8.0	8	1.34	0.78
3	12	8.0-10.5	7	2.47	0.23
4	16	10.5-13.0	6	2.25	1.00

From Table 8, it is known that when sowing mixed soybean seed is in the appropriate series range, the cavity rate and the re-seeding rate can be controlled within the qualified range under the most appropriate operating speed. It proves that the appropriate sowing seed range

and the appropriate operating speed of the planter plate series are reasonably.

## 4 Conclusions

The number of the planter plate series could be effectively reduced by designing the basic size of the seed hole with an effective partition of the seed size range. For the planter plate series with four sizes, the appropriately sowing seed range and the best operating speed are respectively as follows: for the planter plates with the hole diameter of 7, 9, 12, 16 mm, the appropriate size ranges of sowing seeds are 4.5-6.0, 6.0-8.0, 8.0-10.5 and 10.5-13.0 mm respectively, and the appropriate operating speeds are 9, 8, 7, 6 km/h, respectively. Research shows that, this planter plate series seed-metering device can effectively solve the problem of the small sowing seed size range, and can adapt different sizes of soybean seeds filling. It has the characteristics of wide range of application, easy to use, low cost, and high efficiency.

## Acknowledgements

The authors thank the financial support from National Natural Science Foundation of China (51275086).

## [References]

- [1] Liu H X. Study on key parts and holistic device of the soybean dense and flat sowing machine. Beijing: China Agriculture Press, 2007; 29–149. (in Chinese)
- [2] Liu H X, Wang F L, Yang G L. New vertical composite plate soybean precision seed-metering device. Transactions of the CSAE, 2007; 23(10): 112–116. (in Chinese)
- [3] Richard L Parish. Development of a narrow-row vertical-plate planter. Transactions of the ASAE, 1972; 15(4): 636–637.
- [4] Liu H X. Experimental study on optimizing structural parameters of 2B-JP-FL01 seed-metering device. Transactions of the CSAE, 2007; 23(9): 106–110. (in Chinese)
- [5] Zhang Q F, Geng D Y, Li D, Xia L M, Dong Y B. Study on seed-cell filling of the cell structure's size of the horizontal cone frustum type precision meter. Journal of Agricultural Mechanization Research, 2011; 11: 143–147. (in Chinese)
- [6] Yu J M, Holland J B, McMullen M D, Buckler E S. Genetic design and statistical power of nested association mapping in maize. Genetics, 2008, 178: 539–550.

- [7] Zhao K Y, Aranzana M J, Kim S, Lister C, Shindo C, Tang C L, et al. An arabidopsis example of association mapping in structured samples. *PloS Genetics*, 2007; 3(1): 0071–0082.
- [8] Liu Y H, Guan R X, Liu Z X, Ma Y S, Wang L X, Li L H, et al. Genetic structure and diversity of cultivated soybean (*Glycine max* L. Merr.) landraces in China. *Theor. Appl. Genet.*, 2008; 117(6): 857–871.
- [9] Jun T H, Van K, Kim M Y, Lee S H, Walker D R. Association analysis using SSR markers to find QTL for seed protein content in soybean. *Euphytica*, 2008; 162(2): 179–191.
- [10] Liu X F. Association analysis for seed shape traits and 100-seed weight in soybean. Master's thesis, Nanjing Agricultural University, 2010. (in Chinese)
- [11] Deshapande S D, Bal S, Ojha T P. Physical properties of soybean. *Journal of Agricultural Engineering Research*, 1993; 56: 89–98.
- [12] Wang F L, Shang J J, Liu H X, Guo L F. Application of EDEM particles simulation technology on seed-metering device research. *Journal of Northeast Agricultural University*, 2013; 44(2): 110–114.
- [13] Navid H, Ebrahimian S, Gassemzadeh H R, Mousavinia M J. Laboratory evaluation of seed metering device using image processing method. *Australian Journal of Agricultural Engineering (AJAE)*, 2011; 2(1): 1–4.
- [14] Anantachar M, Prasanna G, Kumar V, Guruswamy T. Neural network prediction of performance parameters of an inclined plate seed metering device and its reverse mapping for the determination of optimum design and operational parameters. *Computers and Electronics in Agriculture*, 2010; 72: 87–98.
- [15] Deng X Y, Li X, Shu C X, Huang H D, Liao Q X. Mathematical model and optimization of structure and operating parameters of pneumatic precision metering device for rapeseed. *Journal of Food, Agriculture & Environment*, 2010; 8(3/4): 318–322.
- [16] Vu-Quoc L, Zhang X, Walton O R. A 3-D discrete-element method for dry granular flows of ellipsoidal particles. *Computer Methods in Applied Mechanics and Engineering*, 2000; 187: 483–528.
- [17] Boac J M, Casada M E, Maghirang R G, Harner III J P. Material and interaction properties of selected grains and oilseeds for modeling discrete particles. *Transactions of the ASABE*, 2010; 53(4): 1201–1216.