

Research Team of Mechanized Maize Production

(College of Engineering, China Agricultural University)

The research team of mechanized maize production, based on the support of Key Laboratory of Soil-Machine-Plant System Technology of Ministry of Agriculture and Rural Affairs of China, China Agricultural Research System of Maize, China Agricultural Research System of Legume and College of Engineering of China Agricultural University, focuses on the research of soil sustainability, maize precision seeding, intelligent control of planter, and low damage harvesting technologies, fruitfully providing technical and equipment support for mechanized maize production. The academic leader of the team is Professor Zhang Dongxing, who is the Director of Mechanization Laboratory of China Agricultural Research System of Maize. Now the team members include Professor Yang Li, Associate Professor Cui Tao and Associate Professor Zhang Kailiang, as well as 24 graduate students and doctoral candidates.

Professor Yang Li is the Post Expert of Mechanization Laboratory of China Agricultural Research System of Legume and Member of Expert Group on Scientific and Technological Innovation of National Agricultural Mechanization. Her researches focus on precision variable rate seeding technology, intelligent control technology of agricultural equipment, and high-throughput plant phenotype detection.



Precision seeding technology

Precision seeding technology is an important way to improve the quality of planting and increase productivity and income. Precision seed meter is the key component of precision seeding technology. The team focuses on the research of high-speed precision seeding technology and precision seed meter, and has developed various pneumatic high-speed precision seed meter in the last few years. (1) Inside-filling air-blowing precision seed metering device, with the advantages of simple structure and good adaptability to seeds, achieves good stability in the process of the seeds filled into a filling hole. (2) Air-suction precision seed metering device with aided filling seed plate: The seeds could be held to reduce the possible falling from the seed plate. (3) High-speed air-suction precision seed metering device: Involute finger hole is used to hold seeds stably in order to keep the center of gravity of seeds always in the hole area, which effectively reduces the possible falling from the seed plate during the rotating process.

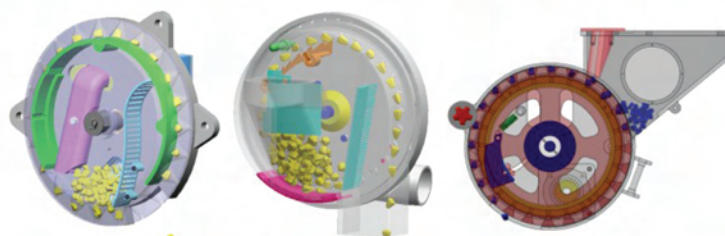

Pneumatic high-speed precision seed meter

Intelligent control technology of planter

Intelligence is the future development trend of planting machine, which can greatly improve the planting performance and save operating costs. In recent years, this team focuses on the research of intelligent control technology and intelligent precision planter. (1) High-speed motor-driving pneumatic intelligent precision seeding control system: The motor-driving control model of the seed-metering device based on GPS was established, which realized the precise synchronization between the machine and seed meter and the stepless regulation of seeding spacing. The bench test and field experiment show that the system has significantly better seeding performance during high speed operation than that of traditional ground wheel chain driving mode. (2) Map-based intelligent control system of variable rate seeding: This system could stably and accurately achieve the variable rate seeding according to a prescription map.

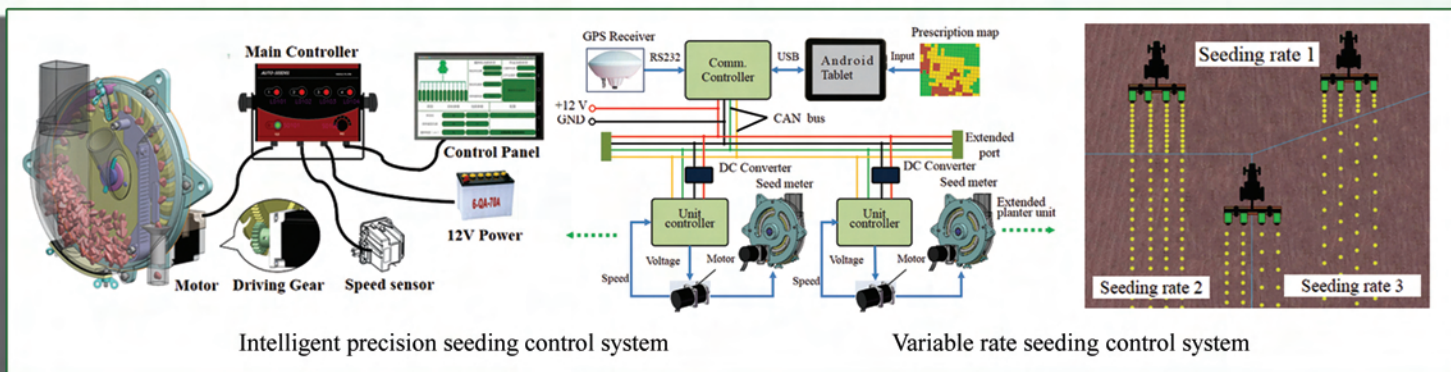

Intelligent precision seeding control system

Variable rate seeding control system

Seeding performance detecting technology

Seeding performance detecting is an important method to evaluate the quality of seed meter. The team focuses on the research and development of seeding performance detecting technology. (1) The seeding performance test stand: By conveniently adjusting seed spacing and forward speed, the test stand could monitor the seeding performance in real time including the qualified feeding index, multiple index, missing index and variation coefficient of seeding spacing. With the simple and convenient installation and disassembly process, the test stand could be applied to different seed meters such as scoop-wheel, finger pick-up, vacuum and air-pressure seed meters. (2) Maize seeding performance remote monitoring system: Android terminal APP is used to set the operation parameters of the seed meter, and MQTT cloud server is established to transfer data to realize simultaneous monitoring of multiple devices without distance limitation. The seeding quality indices plotted by curves in real time are visualized and clear. The system lays a foundation for the development of unmanned farms and intelligent agriculture in China.



Series maize precision planters developed by CAU cooperated with agricultural machinery companies of China



Research Team of Mechanized Maize Production

(College of Engineering, China Agricultural University)

Associate professor Cui Tao of the China Agricultural University, is a young expert in the field of mechanization technology for maize production. His researches focus on low-loss and high-efficiency harvesting technology, precision seeding technology, and optimization design and simulation analysis of agricultural equipment.

Low impurity ear snapping technology



Low damage degranulation separation

pull-roller and plate combined picking mechanism, the newly designed mechanism reduced the impurity content from 6.58% to 3.36%, and the loss rate decreased from 0.06% to 0.03%.

Low seeds damage threshing technology

Aiming at the problem of large grain seeds breakage during direct maize grain harvest, the distribution of the grain and impurities was studied, and the precision control method for the ear-threshing system was proposed. Then a degranulation separation device with low-damage round head nail teeth and segmented combined round tube threshing concave plate was designed. The collision contact between the round head nail teeth and the ear is spherical, which reduced the hitting intensity of the ear, thereby reducing the grain breakage rate. The segmented combined tube threshing concave plate reduced the collision frequency and strength to the ear, and then effectively reduced the grain breaking rate. At the same time, the maize grains were easily separated, avoiding the maize leaves block the concave plate and reducing the entrainment loss. The technical achievements were selected into one of the ten major leading agricultural technologies of the Ministry of Agriculture and Rural Affairs in 2018.

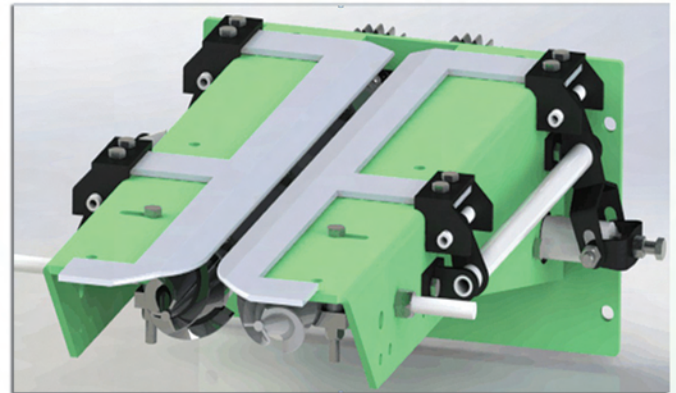

Device of space between of ear-picking plates automatically adjustment

Efficient cleaning technology

To avoid high loss and impurity rate by the cleaning device with high feeding volume when maize grains are directly harvested, the double-layered independent cleaning method was proposed. The influence of the structural parameters of the cleaning device and the working parameters of the fan on the motion of the material on the sieves was studied. A double-layer reverse cleaning device for axial flow combine harvester was designed with compact structure, strong cleaning ability, good cleaning effect and high reliability. The two-layer sieve is independently driven by a crank-link mechanism, which enables combination of different vibration frequencies and vibration amplitudes. The cleaning area is increased to achieve efficient, clean, and low-loss cleaning performance.

Cooperation with Companies

To promote the mechanized harvesting process of maize, the team applied the overall technologies to cooperate with Lovol, Shandong Guofeng Machinery Co., Ltd., and Henan Haofeng Machinery Manufacturing Co., Ltd. The direct maize grain harvesting machines suitable for Northeast, Huanghuaihai, and Southwest hilly mountainous areas have been developed, which provides advanced direct harvesting technology and equipment for main maize producing areas. Relevant technical achievement was selected as one of the top ten new equipment for China agriculture and rural areas in 2017.



Direct maize grain harvesting machines developed by CAU cooperated with agricultural machinery companies of China

Contact: Prof. Yang Li, Associate Prof. Cui Tao, College of Engineering, China Agricultural University,
17 Qinghua East Road, Haidian District, Beijing 100083, China.

Tel: +86-10-62737765, Email: yangli@cau.edu.cn, cuitao850919@163.com



International Journal of Agricultural and Biological Engineering (IJABE)

ISSN 1934-6344, eISSN 1934-6352

Website: <https://www.ijabe.org>