

Real-time remote monitoring system for aquaculture water quality

Luo Hongpin¹, Li Guanglin^{1*}, Peng Weifeng², Song Jie¹, Bai Qiuwei¹

(1. College of Engineering and Technology, Southwest University, Chongqing 400715, China;

2. Department of Electrical Engineering, Chongqing Water Resources and Electric Engineering College 402160, China)

Abstract: A multi-parameters monitoring system based on wireless network was set up to achieve remote real-time monitoring of aquaculture water quality, in order to improve the quality of aquaculture products and solve such problems as being difficult in wiring and high costs in current monitoring system. In the system solar cells and lithium cells were used for power supply. The YCS-2000 dissolved oxygen sensor, pH electrode, Pt1000 temperature sensor and ammonia nitrogen sensor were used to monitor the parameters of aquaculture water quality; STM32F103 chip was used for data processing; Zigbee and GPRS modules were used for data transmission to the remote monitoring center, where the data were stored and displayed. The system was connected with aerator to realize automatic control of dissolved oxygen concentration. The test results showed high confidence level of data transmission with a packet loss rate of 0.43%. Therefore, the system could fulfill the real-time remote monitoring of aquaculture water quality and had great practical significance in reduction of labor intensity, improvement of quality of aquatic products and protection of water environment.

Keywords: aquaculture, water quality, real-time monitoring, wireless sensor network, aerator

DOI: 10.3965/j.ijabe.20150806.1486

Citation: Luo H P, Li G L, Peng W F, Song J, Bai Q W. Real-time remote monitoring system for aquaculture water quality. Int J Agric & Biol Eng, 2015; 8(6): 136–143.

1 Introduction

China has headed the list of total output of aquatic products in the world for consecutive years. With continuous development of aquaculture, aquaculture is becoming more and more intensive and large-scaled, and its species keep on increasing, resulting in continuous deterioration of aquaculture water quality and higher rate of aquaculture diseases. This condition not only deteriorates the aquatic products, causing large economic

loss on aquaculture, but also pollutes severely the water environment. Therefore, fulfillment of the requirement of real-time monitoring on aquaculture water quality to detect the water quality and adjust and control water quality in the deteriorated area in time has great significance on guarantee of quality safety of aquatic products, improvement of culture efficiency and protection of water environment^[1,2].

In recent year, some studies were conducted on wireless monitoring systems of aquaculture water quality, Theofanis et al.^[3] designed a low cost system for real time monitoring of drinking water quality, and based on selected parameters a sensor array is developed for analog signal conditioning, processing, logging, and remote presentation of data. Helmi et al.^[4] used mobile buoy to monitor water quality through GSM, which could go to any location coordinated by the user's command. Muhammad et al.^[5] described an approach of wireless sensor network application to do real-time data collection at the fresh water. Zhou et al.^[6] proposed a water quality monitoring system using wireless sensor networks,

Received date: 2014-10-11 **Accepted date:** 2015-10-21

Biographies: Luo Hongpin, Master, Research interests: intelligent detection. Email: luohongpin89@sina.com; Peng Weifeng, Master, Research interests: mechatronics technology. Email: pwf123456@126.com; Song Jie, Master, Research interests: intelligent detection. Email: 379262495@qq.com; Bai Qiuwei, Master, Research interests: intelligent detection. Email: qiutiandeluweihua@163.com.

***Corresponding author:** Li Guanglin, PhD, Professor. Research interests: intelligent detection and mechatronics technology; College of Engineering and Technology, Southwest University, Chongqing 400715, China. Email: liguanglin@swu.edu.cn, Tel: +86-13883605913.

which used GS1011M as a core to realize function of real-time monitoring of aquaculture. Jiang et al.^[7] designed a system, and the optimized protocol of centralized low-power hierarchical clustering (LEACH-C) for a wireless sensor network communication and frequency control aeration system based on a programmable logic controller (PLC) was adopted. Li et al.^[8] introduced a kind of aquaculture remote monitoring system based on the Internet Android platform, using the system with many sensor nodes, information could be collected remotely by many kinds of sensors. But most of them monitor only a single parameter^[9-11], that means multiple parameters of water environment that influences the growth of fishes cannot be monitored at same time. Meanwhile, they have such disadvantages as short wireless communication distance, high cost, incapability of automatic control of water quality, etc. A real-time monitoring system integrating multiple parameters of aquaculture water quality was studied, to which solar cells and lithium cells are combined for power supply. The system can realize real-time monitoring on dissolved oxygen, pH, temperature, and ammonia nitrogen content in the water. The monitored data were transmitted in wireless method, saved and displayed automatically, so that the dissolved oxygen in water could be controlled automatically. The modular design of the whole system is convenient for installing, debugging and maintaining.

2 General structure of the system

The system consists of power supply, sensor detection part, controller, data transmission part, remote monitoring center, aerator, etc.^[12,13]. The sensor detection part comprises the sensors for dissolved oxygen, pH value, temperature and ammonia nitrogen concentration. The controller is made up of STM32F103 and its peripheral circuits, and is responsible for processing the parameters of water quality acquired by the sensors and controlling the whole system to work properly in order. The data transmission part is composed of Zigbee wireless data transmission module and GPRS module, which transmits the parameters detected by the sensors to the remote monitoring center^[14]. The remote monitoring center is

made up of upper computer, which can realize real-time display, saving, analysis of monitored water quality data. If the controller detects that the dissolved oxygen concentration is lower than the preset lower limit, it will send instructions to start up aerator. When it detects that the dissolved oxygen concentration is higher than the preset upper limit, it shuts down the aerator. Hardware configuration of the system is shown in Figure 1 and the picture of actual sensor node is shown in Figure 2.

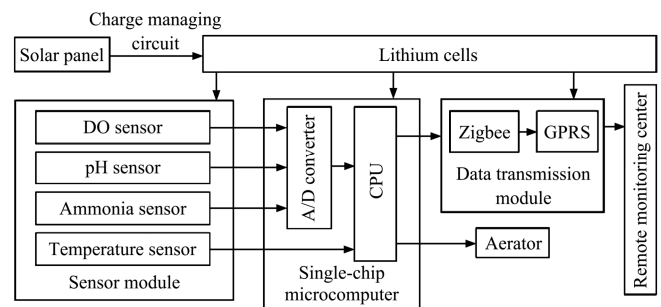

Figure 1 Block diagram of hardware configuration



Figure 2 Actual sensor node of multi-parameters wireless detection system of water quality

3 Design of hardware of monitoring system

3.1 Power supply module

The power supply module consists of lithium battery, solar panels, lithium battery charge-managing circuit and DC/DC step-up/step-down converter circuit.

3.1.1 Power supply by lithium battery

The polymer lithium battery (nominal voltage: 3.7 V, cell capacity: 3.6 A·h) manufactured by New Energy Technology Co., Ltd. was used. In order to fulfill the requirement of working voltage of every module, PT1301 step-up and TPS62007 step-down converters were used to change the output voltage of the lithium battery^[15,16]. The structure diagram of power supply is shown in Figure 3.

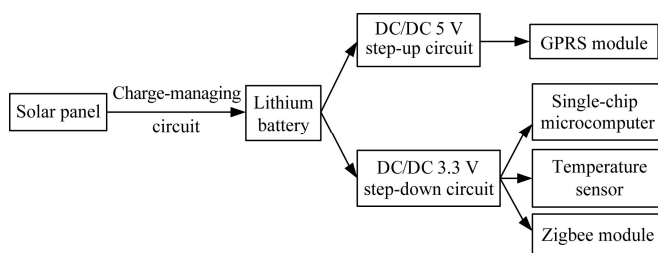

Figure 3 Block diagram of power supply system

Maximum power consumption of the system:

$$P_{sys} = P_{sen} + P_{zig} + P_{GPRS} + P_{mcu} \tag{1}$$

where, P_{sys} is the maximum power consumption of the system, expressed in W; P_{sen} is the maximum power of the temperature sensor, expressed in W; P_{zig} is maximum power of Zigbee module, expressed in W; P_{GPRS} is the maximum power of GPRS module, expressed in W; P_{mcu} is the maximum power of the controller, expressed in W. Since the working voltage of temperature sensor is 3.3 V and working current is 1 mA, $P_{sen}=3.3$ mW. When Zigbee module is working properly, its working voltage is 3.3 V, the maximum working current is 120 mA, so $P_{zig}=396$ mW. When GPRS module is working properly, its working voltage is 5 V and the maximum working current is 500 mA, so $P_{GPRS}=2.5$ W. When the controller is working properly, its working voltage is 3.3 V and working current is 15 mA, so $P_{mcu}=49.5$ mW. It is assumed that the efficiency of 3.3 V voltage-stabilizing module is 80%, that of 5 V module is 70%, it can be derived that:

$$P_{sys} = (3.3 + 396 + 49.5) / 80\% + 2500 / 70\% = 4132 \text{ (mW)} \tag{2}$$

The average power of the system is the weighted mean of the maximum power and the power at sleep state. All parts of the system work twice every day if the aerator is not running while work once every 1 hour if the aerator is running; each work lasts for 10 s. In such way, the average power of the temperature sensor, Zigbee module, GPRS module and controller is 0.0091 mW, 1.375 mW, 9.917 mW and 0.1719 mW respectively. The mean total power of the system is 11.473 mW. Based on 3.7 V voltage of the lithium battery, the average load current of the system is calculated to be 3.1 mA. The correlation between load current and working duration is expressed by $C=I \times t \times \lambda$ (where C is battery capacity, λ is safety factor of service duration of the battery, which is

taken as 1.2), so a 3.4 A·h battery can sustain 914 h operation of the system.

3.1.2 Solar panels

Polycrystalline silicon solar cells (max. current: 0.34 A, max. voltage: 9 V) manufactured by Guangdong Zhaotian Company is used as solar panel. The power output by the solar panel is charged into the lithium battery under the control of charge-managing circuit. The circuit is shown in Figure 4.

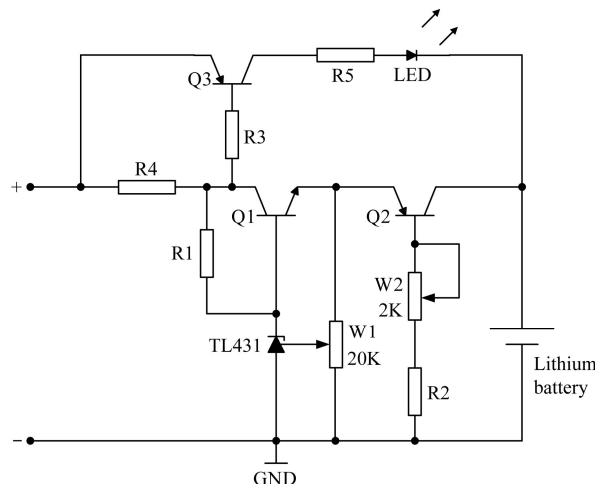

Figure 4 Charge-managing circuit of lithium battery

The controller monitors the voltage of the lithium battery in real time. When the discharge voltage of the lithium battery is lower than 3.6 V, the solar panel begins to charge it. When the voltage reaches 4.2 V, charging stops. The average charge current output by solar panel is 0.13 A. Calculating according to correlation expression $C=I \times t \times \lambda$, and taking 0.8 as the safety factor of charging duration, the average charge duration of the lithium battery is 35 h, and it varies with weather condition.

3.2 Detection module of water quality parameters

The data acquisition module of water quality is composed of sensors and single-chip microcomputer of STM32F103 chip, which has high-efficient Cortex-M3 core and is 72 MHz in working frequency, 2.0-3.6 V in working voltage, -40°C to 85°C in working temperature, provided with built-in high-speed memory. The single-chip microcomputer is low in power consumption, low in voltage and wide in application. It is the core of whole system, used for data acquisition, A/D conversion of acquired signals and controlling the proper working of elements in order. Its control circuit is shown in Figure 5.

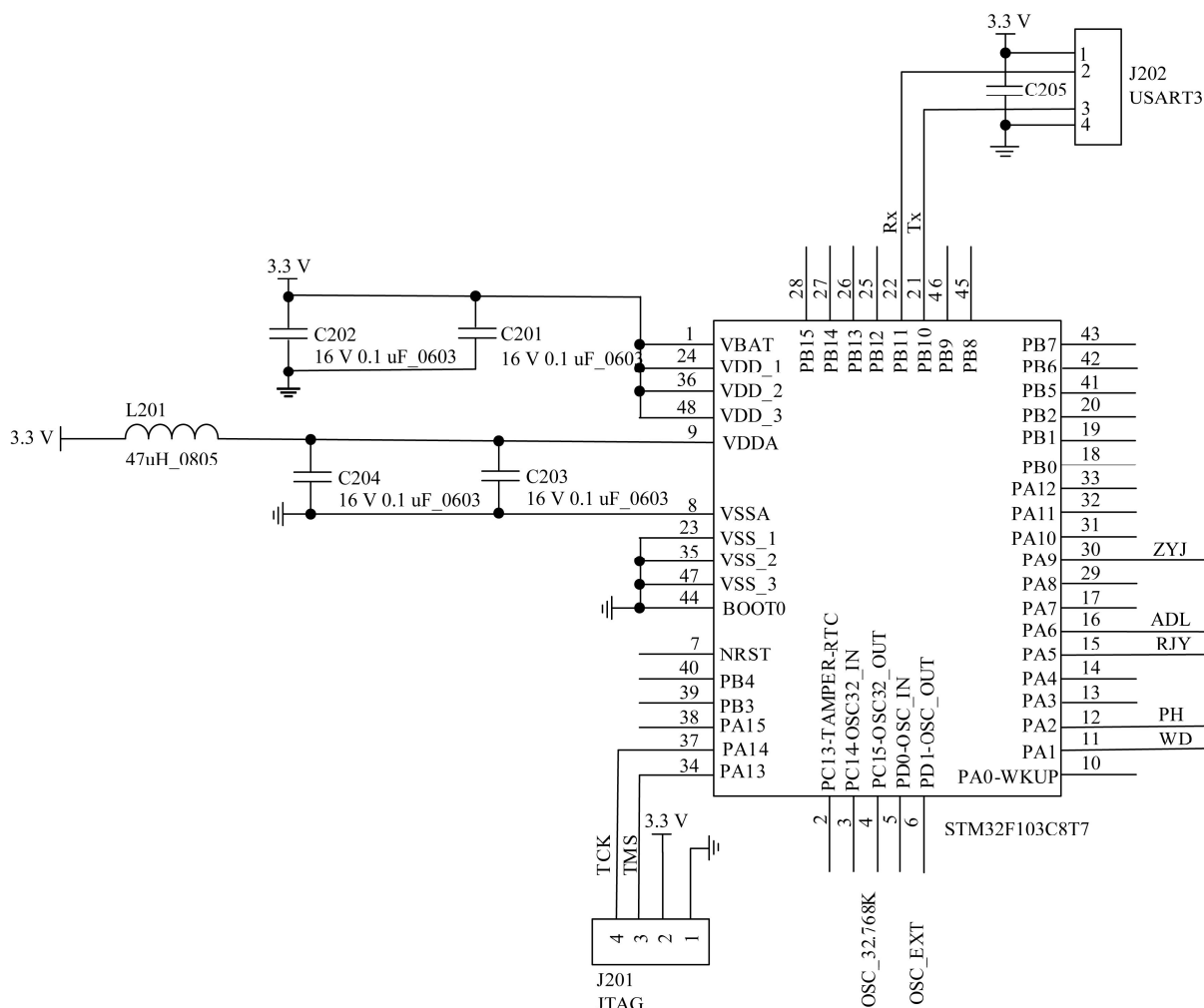

Figure 5 Control circuit of detection unit

YCS-2000 sensor (measurement range: 0-20 mg/L, accuracy: 0.1 mg/L, temperature compensation: 0-40°C) manufactured by Qingdao Yuchang Technology Co., Ltd. was used to detect the concentration of dissolved oxygen. Its signal output end was connected with PA5 port of single-chip microcomputer. A pH composite electrode (measurement range: 0-14, accuracy: 0.02) manufactured by Dongguan House Instrument Co., Ltd. was used to detect pH value. Its signal output end was connected with PA2 port of single-chip microcomputer. Ammonia nitrogen sensor (measurement range: 0-1000 mg/L, accuracy: 0.1 mg/L) manufactured by Shanghai Qingmiao Photoelectric Technology Co., Ltd. was used to detect the ammonia nitrogen concentration. Its output end of signal was connected with PA6 port. The temperature detecting sensor was made up of Pt1000s with measurement accuracy of 0.1°C, and the signal output end was connected with PA1 port of single-chip microcomputer. Its peripheral circuit is shown in Figure 6.

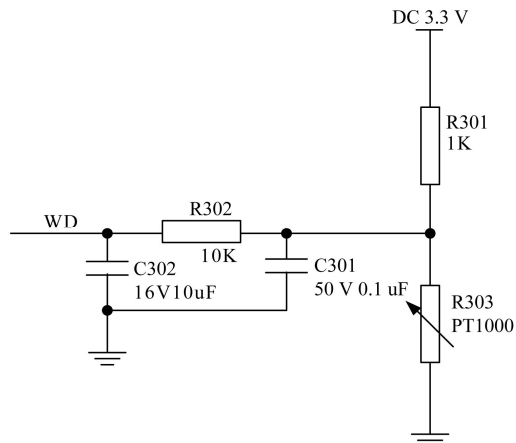

Figure 6 Temperature detecting circuit

3.3 Data transmission module

The data transmission system consists of Zigbee module, GPRS module and remote monitoring center^[17,18]. The monitored data is transmitted to sink via Zigbee module, then to remote monitoring center via GPRS module. The upper computer reads out the data from serial port and displays, saves and analyzes it in real time. Zigbee module is manufactured by Shenzhen

DTK Electronics Co., Ltd. If the module is equipped with external antenna, its transmission distance is up to 1600 m. The working temperature of the module is -40°C to 80°C , the sensitivity is -110 dBm and the frequency is 2.4 GHz. GPRS module (working voltage: 5 V, working temperature: -25°C to 75°C) is manufactured by Jinan USR IOT Technology Limited.

2.4 Aerator module

The aerator module consists of aerator and relay. Impeller-type aerator manufactured by Shanghai Yinba Industrial and Trade Co., Ltd. is adopted, which is ~ 220 V in working voltage and 1.5 kW in power. Photoelectric coupler is used as relay to isolate the input and output signals. When the controller detects the dissolved oxygen concentration less than the lower limit, low level is input from the input end of the photoelectric 0063 coupler, LED and the relay is conductive, then the aerator starts working. When the dissolved oxygen concentration is higher than preset upper limit, 5 V voltage is input from the input end of the photoelectric coupler, its output end is open, and the aerator stops working. In such a way, the dissolved oxygen concentration is controlled^[19]. The control circuit of aerator is shown in Figure 7.

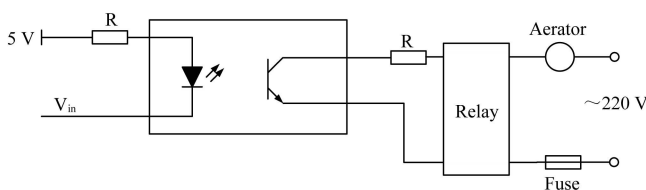

Figure 7 Control circuit of aerator

3 Software design of the system

3.1 Software design of sensor nodes

Program of sensor nodes was developed with Language C based on Keil environment. Modularization design was adopted in the whole programming process, including the modules of system initialization, detection and processing of water quality data, wireless data transmission, and control of aerator. After the system was powered on and reset, it initialized and the timer was started up. The system collected the data of water quality once every 12 h, then saved the collected data into the controller. After data acquisition is completed, the sensors are powered off, and the

controller analyzes and processes the data of water quality and sends it via data transmission module. The controller controls the startup or shutdown of the aerator according to the level of dissolved oxygen concentration (lower than or higher than the thresholds).

The flow diagram of software of remote monitoring system of aquaculture water quality is shown in Figure 8.

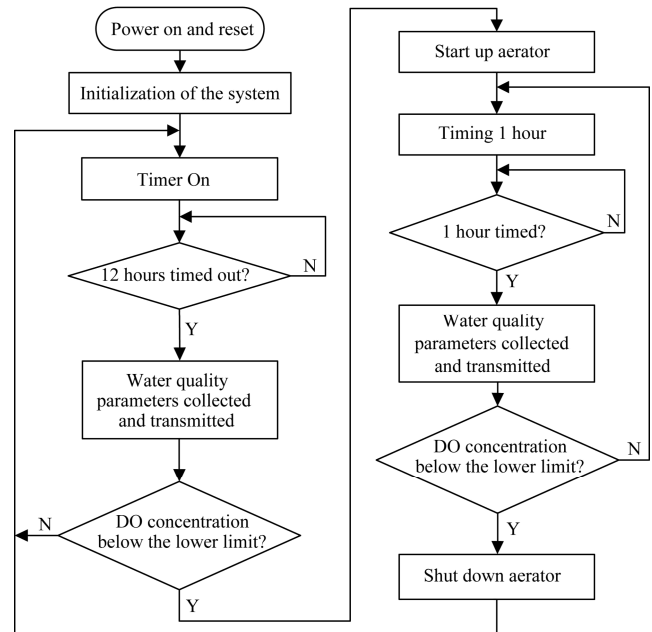

Figure 8 Flow diagram of software of remote monitoring system of aquaculture water quality

3.2 Remote monitoring center

Program of remote monitoring center was developed with Labview, so data acquisition and processing became simpler. The data were transmitted to remote monitoring center via Zigbee and GPRS modules, Labview reads out the data from serial port, and collects, processes, analyzes, saves and displays them. The real-time monitoring screen of water quality parameters are shown in Figure 9.

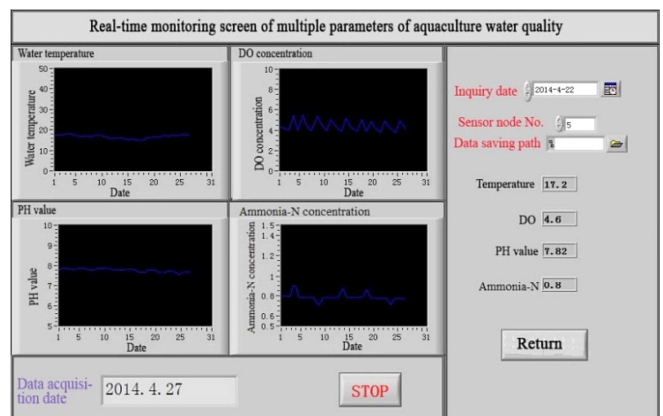

Figure 9 Real-time monitoring screen of water quality

4 Field test and performance analysis

A field test was conducted in an aquaculture area in Chongqing. The aquaculture area is about 2 hm², divided into 16 culture zones. In the test, a sensor detecting unit was set in each culture zone, and a routing node was set in the center of four adjacent culture zones, so four nodes were set totally. A sink was set in the center of the four routing nodes. With reasonable arrangement of position of detecting units, the maximum distance between data transmission nodes in the aquaculture area was 70 m, so Zigbee module could satisfy the transmission requirement. The schematic diagram of structure of the communication system is shown in Figure 10.

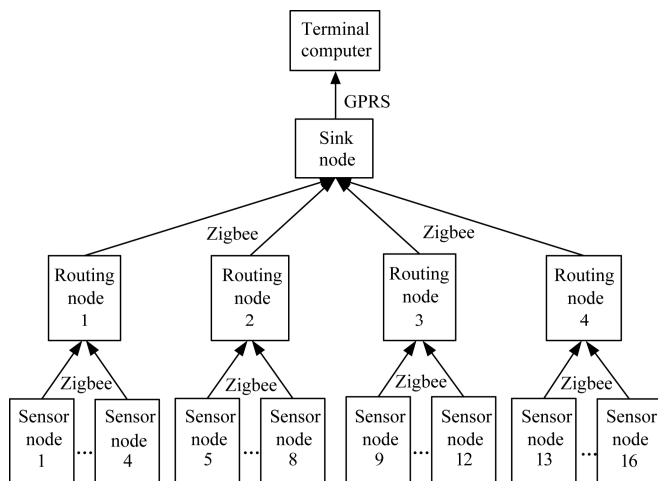

Figure 10 Block diagram of communication system

4.1 Stability analysis of network communication

Network communication was tested on 16 sensor nodes with the aid of “Network Debugging Helper”. The test distance was 100 m without obstruction. The numbers of data packets sent and received were counted. The sensor nodes were set to collect and send data once every 5 min and kept monitoring for consecutive 10 d. The test results are shown in Table 1. It can be found from the table that the average packet loss rate of the network is 0.43%, which is 0.34% higher than the data in current literature^[20,21]. The system runs stably and reliably.

4.2 Stability and reliability analysis of sensor measurement

Sensor stability and reliability analysis were implemented in laboratory by taking 100 L water from

the aquaculture area and using HI83200 multi-parameters water quality quick detector produced by Hanna (of Italy) to test parameters of the water quality. Take the temperature measured by JO-FRADTI1000 high-precision digital temperature detector made by AMETEC (of USA) as standard one. Use the monitoring system described in the Paper to detect the parameters of water quality once every 5 min, and repeat the detection 10 times. The test data is shown in Table 2.

Table 1 Packet loss rate of network

Sensor node	Packet sent	Packet received	Packet loss rate/%
1	2880	2872	0.28
2	2880	2865	0.52
3	2880	2880	0
4	2880	2874	0.21
5	2880	2862	0.63
6	2880	2865	0.52
7	2880	2870	0.35
8	2880	2863	0.59
9	2880	2874	0.21
10	2880	2867	0.45
11	2880	2865	0.52
12	2880	2871	0.31
13	2880	2868	0.42
14	2880	2858	0.76
15	2880	2860	0.69
16	2880	2868	0.42
Average	2880	2867.6	0.43

Table 2 Sensor stability test data

Water quality parameters	Average	Standard value	Standard deviation /%	Mean error /%
Dissolved oxygen/mg·L ⁻¹	4.59	4.6	0.11	0.22
pH	7.84	7.86	0.03	0.25
Ammonia nitrogen/mg·L ⁻¹	0.81	0.8	0.08	1.3
Temperature/°C	19.55	19.5	0.14	0.29

Table 2 shows that the error of 4 quality water parameters is lower 1.5% than standard value and measurement of the system is stable. Each water quality parameter measured by the system all fall in the confidence interval. So it is known that the confidence level of the data measured by the system is high and comply with the design requirement. The cost of the whole system is 15% lower than that detecting the same water quality parameter in the domestic market.

4.3 Working stability analysis of aerator

Since the normal growth of aquatic products will be affected negatively if dissolved oxygen concentration is lower than 4 mg/L, the aerator should be started up

automatically to increase the oxygen concentration when the dissolved oxygen concentration is lower than 4 mg/L and be shut down when the oxygen concentration is higher than 5.5 mg/L (the settings can be adjusted appropriately according to the species of aquatic products), so the limit of dissolved oxygen in the water area is set to be 4.0-5.5 mg/L^[22,23]. Stability analysis of aerator was conducted in water tank in laboratory. Place the water quality parameter detecting unit into the tank, and add sodium sulfite into the tank until the dissolved oxygen concentration is lower than 4 mg/L, observe the operation of the aerator. Then supply oxygen into the tank until the dissolved oxygen concentration is higher than 5.5 mg/L, and observe the operation of the aerator. Repeat the test 10 times and record the operation of the aerator. It is demonstrated by the test results that the system can drive the aerator which can supply oxygen to the water tank according to the preset dissolved oxygen concentration and it works stably and reliably.

4.4 Operating effect test of system

Field test was conducted in aquaculture water area on April 3 to May 2, 2014. The operating effect of the test is described as below:

(1) During the test, the power supply module of solar and lithium battery worked stably, the battery charging happened once and its process lasted for approximately 2 d. So the power supply module can satisfy the power demand of the system.

(2) There are many sultry days during the test. So oxygenation took place for 14 times and each lasted 5-6 h. The aerator works stably and reliably.

(3) Data transmission function of the system was proper. During the test, the remote monitoring center received 576 records about water quality parameters of the aquaculture area in total.

It is demonstrated by the test and the data that all parts of the system can work properly, and each performance reaches the design requirement, so the system can realize remote real-time monitoring of the water quality parameters of aquaculture water area.

5 Conclusions

A real time monitoring system for water quality of

aquaculture area was developed, which integrated the sensors of temperature, pH, dissolved oxygen and ammonia nitrogen, and ZigBee and GPRS transmission techniques. The system was deployed in the aquaculture water with area of 2 hm² and its performance was tested. The average packet loss rate in the network was 0.43%, which meant the data transmission was stable and reliable.

The multi-parameters monitoring system of water quality was connected with aerator to realize to automatic control of dissolved oxygen concentration. But it could not realize automatic control of pH and ammonia nitrogen in the water, which would be studied further in the future.

Acknowledgements

The authors acknowledge that the research was financially supported by “Fundamental Research Funds for the Central Universities (Grant No. XDJK2014D006 and No. 2362014XK13).

[References]

- [1] Liu F F. Determination of ammonia nitrogen in industrial waste water with COD rapid analyzer. Shanxi Chemical Industry, 2011; 31(1): 49–51. (in Chinese with English abstract)
- [2] Han W T, Xu Z Q, Zhang Y, Cao P, Chen X W, Ooi S K. Real-time remote monitoring system for crop water requirement information. Int J Agric & Biol Eng, 2014; 7(6): 37–46.
- [3] Theofanis P. Lambrou, Christos G. Panayiotou. A low-cost system for real time monitoring and assessment of potable water quality at consumer sites. Proc. IEEE Sensors, 2012; pp.1–4.
- [4] Mohd Akmal Helmi A, H, Muhammad Hafiz M, Shah Rizam M. S. B. Mobile buoy for real time monitoring and assessment of water quality. 2014 IEEE Conference on Systems, Process and Control, 12–14 December 2014, Kuala Lumpur, Malaysia.
- [5] Nasirudin M A, Za'bah U N, Sidek O. Fresh water real-time monitoring system based on wireless sensor network and GSM. 2011 IEEE Conference on Open Systems (ICOS2011), Sept. 25–28, 2011, Langkawi, Malaysia.
- [6] Zhou H D, Huang Y, Liu W. Design of water quality monitoring system based on WiFi WSNs. Transducer and Microsystem Technologies, 2015; 34(5): 99–102. (in Chinese)

- with English abstract)
- [7] Jiang J M, Shi G D, Li Z M, Shi B, Huan J. Energy-efficient automatic monitoring system of aquaculture based on WSN. *Transactions of the CSAE*, 2013; 29(13): 166–174. (in Chinese with English abstract)
- [8] Li H, Liu X Q, Li J, Lu X S, Huan J. Aquiculture remote monitoring system based on IOT Android platform. *Transactions of the CSAE*, 2013; 29(13): 175–181. (in Chinese with English abstract)
- [9] Eduardo S, Bastos A C, Miguel N, Fernandes A J, Silva R, Ferreira M G S, et al. New fluorinated diamond microelectrodes for localized detection of dissolved oxygen. *Sensors and Actuators B: Chemical*, 2014; 204: 544–551.
- [10] Liu Q, Li D L, Ma D K, Liang A B, Shi Y. Design of a smart pH value transducer for measuring aquaculture water quality. *Transactions of the CSAE*, 2008; 24(Supp 2): 138–141. (in Chinese with English abstract)
- [11] Daudi S, Simbeye, Shi F Y. Water quality monitoring and control for aquaculture based on wireless sensor networks. *Journal of Networks*, 2014; 9(4): 840–849.
- [12] Li G L, Li X D, Zeng Q X. Development of automatic irrigation and soil moisture monitoring system based on solar energy in citrus orchard. *Transactions of the CSAE*, 2012; 28(12): 145–152. (in Chinese with English abstract)
- [13] Gurkan T, Bilel N, Orhan A, Stelios M. P. Wireless sensor network-based water quality monitoring system. *Key Engineering Materials*, 2014; 605: 47–50.
- [14] Zhang J, Zhang M, Wang L, Wei Q M. The design and realization of mariculture safety testing system based on wireless network. *Journal of the Hebei Academy of Sciences*, 2013; 30(3): 27–31. (in Chinese with English abstract)
- [15] Luo H P, Li G L, Yang F. Research on a Remote Real-time Monitoring System for the Rhizosphere Temperature and Humidity in a Citrus Garden. *Journal of Southwest University*, 2013; 35(12): 131–138. (in Chinese with English abstract)
- [16] Yang S F, Ke J, Zhao J M. Wireless monitoring system for aquiculture environment. *Proceedings of the IEEE International Workshop on Radio-Frequency Integration Technology*, Singapore, 2007; pp.265–268.
- [17] Gui F, Liu X Q. Design for multi-parameter wireless sensor network monitoring system based on ZigBee, *Key Engineering Materials*. 2011; 464: 90–94.
- [18] Guo X M, Zhao C J. Propagation model for 2.4 GHz wireless sensor network in four-year-old young apple orchard. *Int J Agric & Biol Eng*, 2014; 7(6): 47–53.
- [19] Sun D Z, Wang W X, Xu L X, Yu L. Oxygen content automatic monitoring system of the fishpond. *Journal of Agricultural Mechanization Research*, 2005; 7(4): 128–130. (in Chinese with English abstract)
- [20] Huang J Q, Wang W X, Jiang S, Sun D Z, Ou G C, Lu K J. Development and test of aquacultural water quality monitoring system based on wireless sensor network. *Transactions of the CSAE*, 2013; 29(4): 183–190. (in Chinese with English abstract)
- [21] Li X. Study on wireless detection and control system of dissolved oxygen content in fishpond based on GSM technology. Master dissertation. Tianjin: Tianjin University of Science and Technology, 2010. (in Chinese with English abstract)
- [22] Ding, Q S, Dao K M, Li D L, Zhao, L L. Design and implementation of a sensors node oriented water quality monitoring in aquaculture, *Sensor Letters*, 2010; 8(1): 70–74.
- [23] Markogianni V, Dimitriou E, Karaouzas. Water quality monitoring and assessment of an urban Mediterranean lake facilitated by remote sensing applications, *Environmental Monitoring and Assessment*. 2014; 186(8): 5009–5026.