

Physical and mechanical properties of some hybrid corn varieties

Turgut Öztürk*, Bilge Esen

(Department of Agricultural Structure and Irrigation, Faculty of Agriculture, University of Ondokuz Mayıs, 55139 Samsun, Turkey)

Abstract: The aim of this study was to determine the structural designing parameters of silo and bins used for storage of some hybrid corn varieties (*Zea mays* L.). In the research, three corn varieties—dentcorn (*Zea mays indentata* Sturt.), popcorn (*Zea mays everta* Sturt.), sweetcorn (*Zea mays sacharata* Sturt.)—widespread cultivated in Turkey were used. Physico-mechanical parameters (bulk density, true density, angle of internal friction, static coefficient of friction) were considered as the dependent variables, and moisture content (8%, 10%, 12%, and 14%) as the independent variable. The bulk density, true density and angle of internal friction varied from 608.46 to 856.46 kg/m³, 950.88 to 1110.89 kg/m³, and 25.2 ° to 34.2 °, respectively, with the increase in moisture content from 8% to 14%. According to results of the research, the highest average value for bulk density, true density, angle of internal friction were found in popcorn variety (839.17 kg/m³), popcorn variety (1 074.40 kg/m³), sweetcorn variety (30.50 °), respectively. The highest average value for static coefficient of friction at concrete surface (C30) was recorded in dentcorn variety (0.662).

Keywords: corn varieties, physical properties, angle of internal friction, coefficient of friction

DOI: 10.3965/j.ijabe.20130601.0011

Citation: Turgut Öztürk, Bilge Esen. Physical and mechanical properties of some hybrid corn varieties. Int J Agric & Biol Eng, 2013; 6(1): 111–116.

1 Introduction

Corn (*Zea mays* L.) is the main nutrition source in livestock production. For this, corn is one of the major raw materials in feed industry. Besides, it is also used as a raw material in both starch, glucose, oil industry and directly in human nutrition^[1]. The USA is the biggest producer and exporter of corn. The other important countries in the maize cultivation are China, Brazil, Mexico and Argentina^[2]. In 2011, the world's corn production is 883.46 Mt, and Turkey's corn production is 4.20 Mt^[2]. Turkey is one of the countries that are both producer and importer. In Turkey, corn are used in feed

industry (75%), oil + starch + glucose industry (15%), and for the other purposes (15%)^[3].

In the designing of silos, three basic factors should be taken into consideration: the physical–mechanical properties based on formal properties of stored grain, silo geometry, and the interaction between grain and silo wall^[4]. The theoretical basis of grain mechanical properties has been formulated for mineral materials. However, granular materials of biological origin (wheat, barley, soybean, corn, sunflower, etc.), in comparison with mineral-based materials (clay, gravel, sand, crushed stone, etc.) on the particles structure and mechanical properties of bio-based materials, and grain moisture content are largely effective. Therefore, the designing of silos moisture to content of grain should be taken into consideration^[5].

Process design and optimization generate need to determine properties and quality measures of granular materials. Mechanical properties that serve as design parameters for storage systems or processing plants usually depend on properties of individual grains, friction between particles, interparticle contact geometry and load

Received date: 2010-09-03 **Accepted date:** 2013-03-05

Biography: Bilge Esen, Research Assistant, Department of Agricultural Structure and Irrigation, Faculty of Agriculture, University of Ondokuz Mayıs, Samsun, Turkey.

***Corresponding author:** Turgut Öztürk, PhD, Professor, Department of Agricultural Structure and Irrigation, Faculty of Agriculture, University of Ondokuz Mayıs, Samsun, Turkey. Tel: +90-362-3121919/1273; Fax: +90-362-4576034; Email: turgutoz@omu.edu.tr.

history. Recently, in response to demand of industrial practice, several silo design codes were revised, including standardization of methods and equipment for determination of mechanical properties of granular materials^[6]. In Eurocode 1, three tests are recommended for determination of a set of parameters: direct shear, triaxial compression and uniaxial compression^[7].

The physical and mechanical properties of corn depended on variety are important to design the storage structures and the selection of storage equipments. Designing such storage structures and selection of storage equipments without taking these into consideration may yield poor results. Therefore, the determination and consideration of properties such as bulk density, true density, angle of internal friction, static coefficient of friction of grain has an important role^[5,8].

The objective of this study was to determine the structural designing parameters of silo and bins used for storage of some hybrid corn varieties (*Zea mays* L.) widespread cultivated in Turkey.

2 Materials and methods

2.1 Sample preparation

Hybrid corn varieties (dentcorn, popcorn and sweetcorn) used in the research were obtained from the Black Sea Agricultural Research Institute in Samsun province, in Turkey (Figure 1). Firstly, hybrid corn varieties brought to laboratory were cleaned manually to remove all foreign and other fine material. The equilibrium moisture content (EMC) of grains was determined by oven drying at $(75 \pm 5)^\circ\text{C}$ for 10 h^[9,10]. While the experimental samples was dried to achieve for conditions over the EMC, Equation (1) was used for the conditions below the EMC and then this amount was added to the moisture^[11].

$$Q = \frac{W_i(M_f - M_i)}{100 - M_f} \quad (1)$$

The samples were filled into polyethylene bags individually and then closed, before kept in a curing room for three days to make the moisture to distribute uniformly throughout the grains. After the grains reached the EMC, it was placed in desiccators and stored at room temperature of $(23 \pm 2)^\circ\text{C}$ before use. Before each

test, the required quantity of samples were taken out of desiccators and allowed to warm up to room temperature.



Figure 1 Hybrid maize varieties used in research

2.2 Determination of physical properties

The bulk and true densities of hybrid corn varieties were determined separately at different moisture contents of 8%, 10%, 12%, and 14% (d.b.). The bulk density container of 1 000 mL volume and 108 mm height was used to determine bulk densities of experimental samples. The bulk density container was filled up to 5 cm above the top. The corn samples were then allowed to settle into the container and the bulk density was calculated from Equation (2)^[12,13].

$$\gamma = \frac{G_2 - G_1}{V} \quad (2)$$

The liquid displacement method was used to determine the true density of hybrid corn varieties^[14,15]. In this method, toluene (C_7H_8) was used in place of water because it is absorbed to a lesser extent by corn samples and its surface tension is low. To calculate true density, the air dried weight for samples was first determined. The samples were then submerged in toluene and the displacement volume was determined. In the second stage, the true density of samples was calculated by Equation (3) as follows.

$$\rho = \frac{m_s + m_w}{V_s + V_w} \quad (3)$$

2.3 Determination of mechanical properties

To determine the angle of internal friction of hybrid, corn varieties at different moisture contents were used by the direct shear method^[16-18] (Figure 2). The velocity used during the experiment was 0.7 mm/min and the angle of internal friction of samples was calculated by Equations (4), (5) and (6) as follows.

$$\sigma = \frac{N}{A} \times 100 \quad (4)$$

$$\tau = \frac{T_s}{A} \times 100 \tag{5}$$

$$\tau = (c + \sigma \times \text{tg}\phi) \tag{6}$$

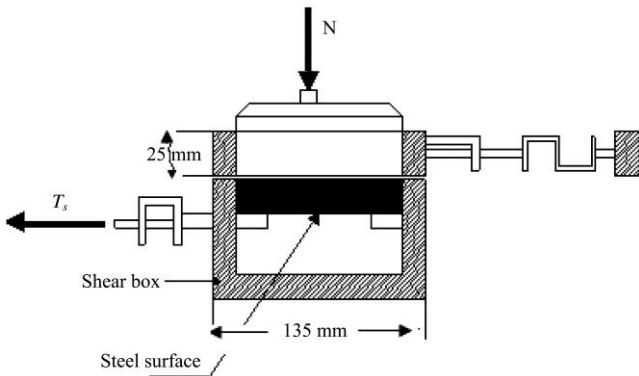

Figure 2 Direct shear box apparatus

To determine the static coefficients of friction of corn samples as friction surfaces in experiments were wood, concrete (C30) and galvanized steel surfaces were used^[19]. During the experiment, the test surface moved at a low velocity (2.4 cm/s). The surfaces were driven by a 12 V, adjustable direct current motor and strength of friction was measured by a digital dynamometer (Figure 3). The static coefficient of friction was calculated from the constant strength of friction read in the digital dynamometer after movement occurred at the interface. The static coefficients of friction of the samples were calculated by Equation (7).

$$\mu_s = \frac{F_s}{W} \tag{7}$$

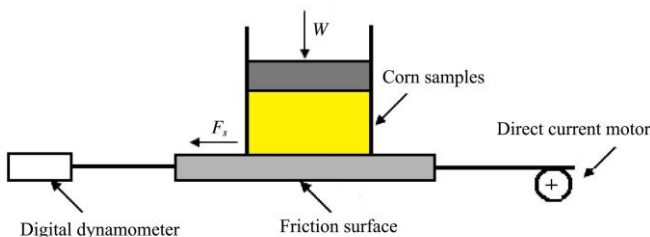

Figure 3 Apparatus to measure the force required to cause two surfaces to slide

2.4 Data analysis

All these experiments were replicated three times, unless stated otherwise, and the average values are reported. All the data obtained were analysed statistically using the SPSS 13 statistical programme. Duncan’s multiple comparison was used to determine

differences exist at a 1% level of significance among the corn varieties.

3 Results and discussion

3.1 Physical properties

The EMC of hybrid corn varieties employed in the study are presented in Table 1. The EMC varied between 8.0% and 9.5% (d.b.). The bulk densities and standard errors of hybrid corn varieties at different moisture levels are presented in Table 2. The bulk densities varied between 608.46 kg/m³ and 856.46 kg/m³, depending on moisture content. The bulk density of corn varieties decreases with increase in moisture content. This is due to the higher rate of increase in volume than that in weight.

Table 1 Equilibrium moisture content (EMC) of hybrid corn varieties

Corn varieties	Moisture content/%, d.b.
Pop corn (<i>cin</i>)	8.0
Dent corn (<i>karadeniz yıldızı</i>)	9.0
Sweet corn (<i>şeker</i>)	9.5

Table 2 Bulk densities of hybrid corn varieties and standard errors

Moisture content (% , d.b.)	Bulk density (γ) (kg · m ⁻³)		
	Popcorn (<i>cin</i>)	Dentcorn (<i>kar.yıl.</i>)	Sweetcorn (<i>şeker</i>)
8	856.46 ± 1.56	799.90 ± 27.17	641.47 ± 3.95
10	843.57 ± 0.49	797.50 ± 23.42	631.54 ± 0.88
12	832.49 ± 0.63	794.20 ± 18.65	619.33 ± 3.27
14	826.15 ± 1.24	792.86 ± 15.63	608.46 ± 1.60

The negative linear relationship between the moisture content and bulk density was found in some studies conducted on sunflower and cotton seeds^[20,21]. The statistical analysis of experimental data showed that, related to bulk density, the relationship between varieties and interaction of variety and moisture was highly significant ($P < 0.01$). The results of analysis of regression determined by regression equations and R^2 values were given as follows:

$$\gamma_{\text{popcorn} (cin)} = 895.77 - 5.10M_c \quad (R^2 = 0.98)$$

$$\gamma_{\text{dentcorn} (kar.yıl.)} = 809.55 - 1.22M_c \quad (R^2 = 0.97)$$

$$\gamma_{\text{sweetcorn} (şeker)} = 686.38 - 5.56M_c \quad (R^2 = 0.99)$$

The variation of true density with moisture contents for corn varieties are shown in Table 3. The Table 3

indicates that the true densities depended on moisture content are to vary according to the varieties. Relative increase in weight is not proportional to volumetric increase. The true density of corn varieties is dependent on the physical characteristics and its moisture content. In some researches on pigeon pea, karingha seeds, chickpea, the negative linear relationship between the moisture content and true density was observed^[22-24]. The statistical analysis of experimental data showed that, relative to true density, the relationships between varieties and moisture content were highly significant ($P<0.01$), as confirmed by the R^2 values below.

$$\rho_{\text{popcorn (cin)}} = 1184.70 - 10.02M_c \quad (R^2 = 0.93)$$

$$\rho_{\text{dent corn(kar.yil.)}} = 979.15 - 1.99M_c \quad (R^2 = 0.99)$$

$$\rho_{\text{sweet corn (seker)}} = 925.3215 + 3.94M_c \quad (R^2 = 0.99)$$

Table 3 True densities of hybrid corn varieties and standard errors

Moisture content (%, d.b.)	True density (ρ)/kg · m ⁻³		
	Popcorn (<i>cin</i>)	Dentcorn (<i>kar.yil.</i>)	Sweetcorn (<i>seker</i>)
8	1110.89±1.00	963.18±1.03	956.25±0.73
10	1076.91±0.63	958.90±0.16	965.40±0.62
12	1060.14±1.91	955.94±0.71	972.77±0.75
14	1049.66±0.26	950.88±0.99	980.03±0.84

3.2 Mechanical properties

Angles of internal friction of hybrid corn varieties and standard error values are presented in Table 4. The angle of internal friction was found to increase with increase in moisture content. The positive linear relationship between angle of internal friction and moisture content was determined. Similar results have been observed in some studies on locust bean seed, Turkish mahaleb, lentil grains, fenugreek seeds and pomegranate seeds^[25,29]. The statistical analysis of data concerning angle of internal friction showed that the interaction between variety and moisture is significant ($P<0.01$). The results of regression analysis, as determined by regression equations and R^2 values, were given as follows:

$$\phi_{\text{popcorn (cin)}} = 19.31+0.97M_c \quad (R^2 = 0.97)$$

$$\phi_{\text{dent corn(kar.yil.)}} = 20.29+0.86M_c \quad (R^2 = 0.99)$$

$$\phi_{\text{sweet corn (seker)}} = 14.55+1.45M_c \quad (R^2 = 0.93)$$

Table 4 Angles of internal friction of corn varieties and standard errors

Moisture content (%, d.b.)	Angle of internal friction (ϕ), degree		
	Popcorn (<i>cin</i>)	Dentcorn (<i>kar.yil.</i>)	Sweetcorn (<i>seker</i>)
8	27.2±0.17	27.2±0.17	25.2±0.60
10	29.0±0.58	28.8±0.60	30.3±0.67
12	30.3±0.33	30.7±0.33	32.3±0.73
14	33.2±0.17	32.3±0.33	34.2±0.17

Depending on moisture content and surface (wood, concrete, steel), the static coefficients of friction and standard errors for corn varieties are presented in Table 5. The static coefficients of friction of corn varieties increased linearly with moisture content and varied according to the surface. As the highest value for static coefficient of friction was recorded in dentcorn (*Karadeniz yıldızı*) variety at 14% moisture content and concrete surface (0.738), the lowest value for static coefficient of friction was determined in popcorn (*cin*) variety at 8% moisture content and wood surface (0.274). The statistical analysis of experimental data showed that, relative to varieties, moisture content and friction surface had highly significant effects on the static coefficient of friction ($P<0.01$). Regression equations related to the static coefficient of friction for hybrid corn varieties and R^2 values are presented in Table 6. Some researchers reported that as the moisture content increased, the static coefficient of friction increased^[20,30-32].

Table 5 Static coefficients of friction of corn varieties

Corn variety	Moisture content (%, d.b.)	Test surface		
		Concrete	Galvanized steel	Wood
Dentcorn (<i>kar.yil.</i>)	8	0.578±0.016	0.532±0.003	0.346±0.002
	10	0.633±0.008	0.585±0.001	0.360±0.003
	12	0.698±0.003	0.631±0.005	0.389±0.005
	14	0.738±0.014	0.654±0.011	0.450±0.020
Popcorn (<i>cin</i>)	8	0.459±0.006	0.339±0.002	0.274±0.002
	10	0.480±0.003	0.357±0.000	0.288±0.000
	12	0.511±0.005	0.454±0.007	0.347±0.004
	14	0.530±0.003	0.488±0.003	0.360±0.002
Sweetcorn (<i>seker</i>)	8	0.523±0.009	0.457±0.009	0.322±0.015
	10	0.587±0.009	0.527±0.009	0.371±0.006
	12	0.627±0.003	0.573±0.003	0.404±0.003
	14	0.660±0.006	0.603±0.009	0.437±0.090

Table 6 Regression equations related to the static coefficients of friction of corn varieties

Surface	Corn varieties	Regression equations
Concrete	Dentcorn (<i>kar.yıl.</i>)	$\mu_s = 0.362 + 0.0273M_c (R^2 = 0.99)$
	Popcorn (<i>cin</i>)	$\mu_s = 0.361 + 0.0122M_c (R^2 = 0.99)$
	Sweetcorn (<i>şeker</i>)	$\mu_s = 0.351 + 0.0226M_c (R^2 = 0.98)$
Galvanized steel	Dentcorn (<i>kar.yıl.</i>)	$\mu_s = 0.374 + 0.0206M_c (R^2 = 0.97)$
	Popcorn (<i>cin</i>)	$\mu_s = 0.110 + 0.0272M_c (R^2 = 0.93)$
	Sweetcorn (<i>şeker</i>)	$\mu_s = 0.274 + 0.0242M_c (R^2 = 0.97)$
Wood	Dentcorn (<i>kar.yıl.</i>)	$\mu_s = 0.1987 + 0.0171M_c (R^2 = 0.91)$
	Popcorn (<i>cin</i>)	$\mu_s = 0.143 + 0.0158M_c (R^2 = 0.92)$
	Sweetcorn (<i>şeker</i>)	$\mu_s = 0.176 + 0.0189M_c (R^2 = 0.99)$

4 Conclusions

The conclusions of this paper can be summarized as follows:

1) EMC of hybrid corn varieties (*Zea mays* L.) were found to be from 8.0 % to 9.5 % (d.b).

2) As the moisture content increased from 8% to 14% (d.b), bulk density decreased at all corn varieties. The highest average value for bulk density was found in popcorn variety ($\gamma = 839.17 \text{ kg/m}^3$).

3) In all other varieties except popcorn, as the moisture content increased from 8% to 14% (d.b), true density decreased. The highest average value for true density was found in popcorn variety ($\rho = 1074.40 \text{ kg/m}^3$).

4) Angle of internal friction of corn varieties increases with increase in moisture content. The positive linear relationship between angle of internal friction and moisture content was determined. The highest average value for angle of internal friction was found in sweet corn variety (30.50 °).

5) The static coefficients of friction of corn varieties increased linearly with moisture content and varied according to the surface. As the highest value for static coefficient of friction was recorded in dentcorn (*Karadeniz yıldızı*) variety in 14% moisture content and concrete surface (0.738), the lowest value for static coefficient of friction was determined in popcorn (*cin*) variety in 8% moisture content and wood surface (0.274).

Nomenclature

Q amount of added water, g

W_i	dry sample weight, g
M_i	initial moisture content of sample, %
M_f	final moisture content of sample, %
γ	bulk density, kg/m^3
G_1	free weight of bulk density bucket, kg
G_2	weight of bulk density bucket with corn grains, kg
V	inner volume of bulk density bucket, m^3
ρ	true density, kg/m^3
m_s	weight of liquid, kg
m_w	weight of air dry sample, kg
V_s	volume of liquid, m^3
M_c	moisture content, %
V_w	volume of sample, m^3
σ	normal stress, kPa
N	load applied on the sample, kN
A	cellular area, cm^2
τ	shear stress, pressure on cutting edge, kPa
T_s	shear force, load on cutting edge, kN
c	coefficient of cohesion
ϕ	angle of internal friction, degree
μ_s	static coefficient of friction
F_s	force starting movement at surface interface, kN
W	force applied to surface interface, kN

Acknowledgements

The authors would like to thank Project Management Office of Ondokuz Mayıs University for financial support to this project (Z-479).

[References]

- [1] Vyn R, Marchand L. The economic importance of Ontario's corn sector. University of Guelph, Ontario, Canada. 2005.
- [2] FAOSTAT, World crop production statistics. Available at [<http://faostat.fao.org>], 2011.
- [3] Koca Y, O, Ereku O, Ünay A, Turgut İ. Evaluation of main and second crop performances of some hybrid corn (*Zea mays* L.) varieties grown in Aydın Province. Journal of Adnan Menderes University Agriculture Faculty, 2009; 6(1): 41–52.
- [4] Ayuga F, Aguado P, Gallego E, Ramirez A. New steps towards the knowledge of silos behaviour. International Agrophysics, 2005; 19(1): 7–17.

- [5] Molenda M, Horabik J, Thompson S A, Ross I J. Effects of grain properties on loads in model silo. *International Agrophysics*, 2004; 18(4): 329–332.
- [6] Stasiak M, Molenda M, Horabik J. Determination of modulus of elasticity of cereals and rapeseeds using acoustic method. *Journal of Food Engineering*, 2007; 82(1): 51–57.
- [7] Eurocode 1. Basis of design and actions on structures – Part 4: Actions in silos and tanks. In European Committee for Standardization. Central Secretariat: rue de Stassart 36, B-1050 Brussels, 2003.
- [8] Kashaninejad M, Mortazavi A, Safekordi A, Tabil L G. Some physical properties of pistachio (*Pistacia vera* L.) nut and its kernel. *Journal of Food Engineering*, 2006; 72(1): 30–38.
- [9] AOCS. Official methods and recommended practices of the American Oil Chemists' Society. 5th Ed. AOCS Press, Champaign, IL (USA), 1998.
- [10] Yağcıoğlu A. Drying technique of agricultural products. Ege University, Faculty of Agriculture, Publish Number: 536, İzmir, Turkey (in Turkish). 1999.
- [11] Balasubramanian D. Physical properties of raw cashew nut. *Journal of Agricultural Engineering Research*, 2001; 78(3): 291–297.
- [12] Mohsenin N N. Structure, physical characteristics and mechanical properties of plant and animal materials. Gordon and Breach Science Publishers, New York. 1980.
- [13] Singh K K, Goswami T K. Physical properties of cumin seed. *Journal of Agricultural Engineering Research*, 1996; 64(1): 93–98.
- [14] Aydın C. Physical properties of hazelnuts. *Biosystems Engineering*, 2002; 82(3): 297–303.
- [15] Abalone R, Cassinera A, Gaston A, Lara M A. Some physical properties of amaranth seeds. *Biosystems Engineering*, 2004; 89(1): 109–117.
- [16] Zou Y, Brusewitz G H. Angle of internal friction and cohesion of consolidated ground marigold petals. *Transactions of the ASAE*, 2001; 44: 1255–1259.
- [17] Molenda M, Montross M D, Horabik J, Ross I J. Mechanical properties of corn and soybean meal. *Transactions of the ASAE*, 2002; 45: 1929–1936.
- [18] Çağlı S. Determination of flow properties of bulk solids and silo design (unpublished Master's thesis). Istanbul Technical University, Graduate School of Science, Department of Chemical Engineering, Istanbul, Turkey. 2005.
- [19] Kibar H, Öztürk T. The effect of moisture content on the physico-mechanical properties of some hazelnut varieties. *Journal of Stored Products Research*, 2009; 45(1): 14–18.
- [20] Gupta R K, Das S K. Some physical properties of sunflower seeds. *Journal of Agricultural Engineering Research*, 1997; 66: 1–8.
- [21] Özarslan C. Physical properties of cotton seed. *Biosystems Engineering*, 2002; 83 (2): 169–174.
- [22] Shepherd H, Bhardwaj R K. Moisture dependent physical properties of pigeon pea. *Journal of Agricultural Engineering Research*, 1986; 3: 227–234.
- [23] Suthar S H, Das S K. Some physical properties of karingda seeds. *Journal of Agricultural Engineering Research*, 1996; 65: 15–22.
- [24] Konak M, Çarman K, Aydın C. Physical properties of chick pea seeds. *Biosystems Engineering*, 2002; 82(1): 73–78.
- [25] Ogunjimi A O, Aviara N A, Aregbesola O A. Some engineering properties of locust bean seed. *Journal of Food Engineering*, 2001; 55(2): 95–99.
- [26] Aydın C, Ögüt H, Konak M. Some physical properties of Turkish mahaleb. *Biosystems Engineering*, 2002; 82(2): 231–234.
- [27] Amin M N, Hossain M A, Roy K C. Effect of moisture content on some physical properties of lentil grains. *Journal of Food Engineering*, 2003; 65: 83–87.
- [28] Altuntaş E, Özgöz E, Taşer Ö F. Some physical properties of fenugreek seeds. *Journal of Food Engineering*, 2004; 61–66.
- [29] Kingsly A R P, Singh D B, Manikantan M R, Jain R K. Moisture dependent physical properties of dried pomegranate seeds. *Journal of Food Engineering*, 2005; 75(4): 492–496.
- [30] Çarman K. Some physical properties of lentil seeds. *Journal of Agricultural Engineering Research*, 1996; 63: 87–92.
- [31] Baryeh E A. Physical properties of millet. *Journal of Food Engineering*, 2002; 51: 39–46.
- [32] Dursun E, Dursun İ. Some physical properties of caper seeds. *Biosystems Engineering*, 2005; 92(2): 237–245.